

KD-2 type

Available from 2Ton to 5Ton capacity



KD-2 type

- Hoist classification : FEM(1Bm) / ISO(M3)
- Motor & brake class : "F" class
- Ambient temperature : -20°C ~ +40°C
- Intermittent Rating(%ED) :
single speed(25%ED) / dual speed(20%ED)

- Mechanical brake system
- Upper/lower limit switch
- DC brake system
- Emergency stop
- Powerful motor
- KD manufactured load chain

I STANDARD SPECIFICATION

Model	Capacity (ton)	Lift (m)	Duty rating (min)		Lifting Speed (m/min)				Traversing Speed (m/min)		Load Chain Dia. (mm)	No. of Falls of Load Chain	Test Load (kg)
			Single	Dual	Single		Dual		50Hz	60Hz			
					50Hz	60Hz	50Hz	60Hz					
KD-2	2	4	30	5/15	6.8	8.2	6.8/1.7	8.2/2.0	-	-	φ11.2	1	2,500
	2.8	4	30	5/15	4.3	5.2	4.3/1.1	5.2/1.3	-	-	φ9.5	2	3,500
	3	4	30	5/15	4.3	5.2	4.3/1.1	5.2/1.3	-	-	φ9.5	2	3,750
	5	4	30	5/15	3.0	3.6	3.0/0.8	3.6/0.9	-	-	φ11.2	2	6,250
KD-2M	2	4	30	5/15	6.8	8.2	6.8/1.7	8.2/2.0	10	12	φ11.2	1	2,500
	2.8	4	30	5/15	4.3	5.2	4.3/1.1	5.2/1.3	10	12	φ9.5	2	3,500
	3	4	30	5/15	4.3	5.2	4.3/1.1	5.2/1.3	10	12	φ9.5	2	3,750
	5	4	30	5/15	3.0	3.6	3.0/0.8	3.6/0.9	10	12	φ11.2	2	6,250

Capacity (ton)	Output (kw)		Traversing (kw)	Net weight		Extra weight per 1m lift (kg)	
	Single	Dual		KD-2	KD-2M	KD-2	KD-2M
2	3.3	3.3/0.825	0.4	137 (147)	177 (187)	2.7	2.7
2.8	3.3	3.3/0.825	0.4	151 (161)	208 (218)	4.0	4.0
3	3.3	3.3/0.825	0.4	151 (161)	208 (218)	4.0	4.0
5	3.3	3.3/0.825	0.4	160 (170)	243 (253)	5.3	5.3

I DIMENSION

Model	Capacity (ton)	Dimension (mm)											Std.I-Beam Width (mm)	Min. Radius of Curve (mm)
		A	B	C	D	E	F	H	S	W	P	G		
KD-2	2	307	355 (392)	168	168	-	34	-	-	50	805	790	-	-
	2.8	307	355 (392)	113	223	-	41	-	-	60	895	970	-	-
	3	307	355 (392)	113	223	-	41	-	-	60	895	970	-	-
	5	307	355 (392)	113	223	-	48	-	-	67	970	1,095	-	-
KD-2M	2	307	355 (392)	125	245	418	34	123	296	60	770	755	100, 125, 150	1,500
	2.8	307	355 (392)	125	254	357	41	136	337	60	900	925	100, 125, 150	1,500
	3	307	355 (392)	125	254	357	41	136	337	60	900	925	100, 125, 150	1,500
	5	307	355 (392)	150	270	443	48	158	384	67	950	1,054	125, 150, 175	2,000

() Dual speed Dimension, Specification

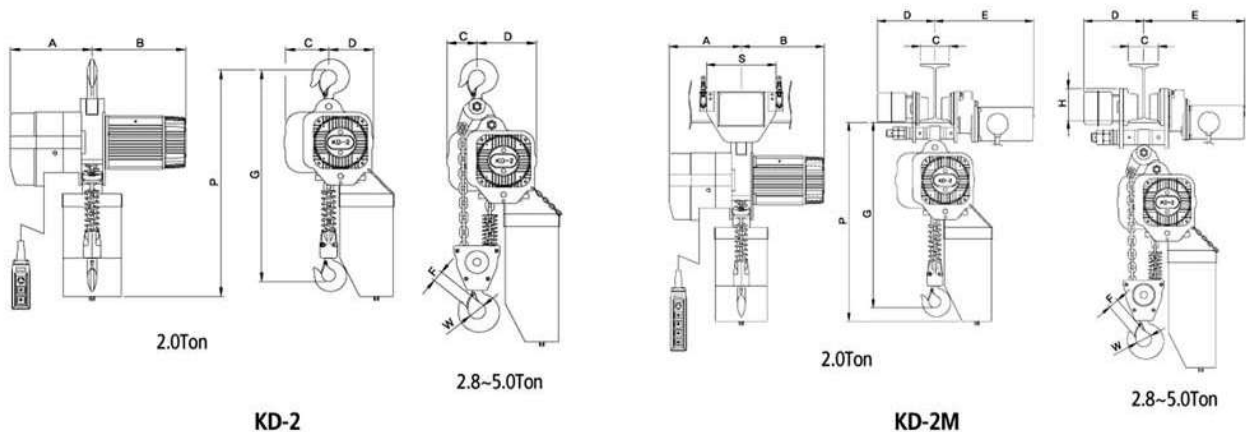

• The design, material and specification are subject to change for improvement without notice.
 • A special specification is available upon request.
 • 곡동호이스트(주) 제품의 규격은 품질개선을 위하여 예고없이 변경될 수 있으므로 제품 구입시 문의바랍니다.

※ F 치수는 안전고리 제외된 치수임