

Electric wire rope hoists T10 Conveying one with one trolley, reeving 2/1

(1) with micro-lifting

(2) with load limitation

(3) with load limitation and with micro-lifting

Type	Reeving 2/1		Dimensions, mm																										
	Lifting height, m	Lifting capacity, kg	Lifting speed m/min				L2	L3	L4	L5	L6	L7	H1	H2	H3	B	B1	B2	B3	B4	B5	e	C	D					
			8	12	8/2	12/2																							
T102...	H1	6	500	648	688	287	225	37	45	415	46	148	204	33	90...	465	300	94...	245...	34	18	850	120						
	H2	9		738	778										332	60								68	130	492 ⁽¹⁾	365 ⁽²⁾	54	305
	H3	12		818	858										373	80								88	557 ⁽³⁾				
T103...	H1	6	1000	709	749	310	225	48	55	415	70	148	204	33	90...	465	300	94...	245...	40	18	910	120						
	H2	9		814	854										362	75								82	130	492 ⁽¹⁾	365 ⁽²⁾	54	305
	H3	12		914	954										412	100								106	557 ⁽³⁾				
T104...	H1	6	2000	816	880	362	280	45	51	536	80	200	272	42	130...	580	380	125...	270...	45	22	1120	175						
	H2	9		926	990										417	73								79	150	606 ⁽¹⁾	442 ⁽²⁾	105	335
	H3	12		1026	1090										467	96								104	668 ⁽³⁾				
T105...	H1	6	3200	856	923	377	280	52	59	536	80	200	272	42	130...	580	380	125...	270...	50	22	1200	175						
	H2	9		976	1043										437	82								89	150	606 ⁽¹⁾	442 ⁽²⁾	105	335
	H3	12		1086	1153										492	110								116	668 ⁽³⁾				
T106...	H1	6	5000	905	993	395	310	49	66	595	90	232	317	33	130...	675	430	145...	300...	56	26	1380	210						
	H2	9		1010	1098										448	75								82	150	682 ⁽¹⁾	508 ⁽²⁾	125	365
	H3	12		1115	1203										500	101								108	760 ⁽³⁾				

Type	Reeving 2/1		Lifting speed m/min			
	Lifting height, m	Lifting capacity, kg	8	12	8/2	12/2
			Weight, kg			
T102...	H1	6	500	129	147	
	H2	9		135	153	
	H3	12		138	156	
T103...	H1	6	1000	137	160	
	H2	9		142	165	
	H3	12		152	175	
T104...	H1	6	2000	290	337	
	H2	9		305	352	
	H3	12		315	362	
T105...	H1	6	3200	325	335	390
	H2	9		340	350	405
	H3	12		355	365	420
T106...	H1	6	5000	488	583	
	H2	9		508	603	
	H3	12		528	623	

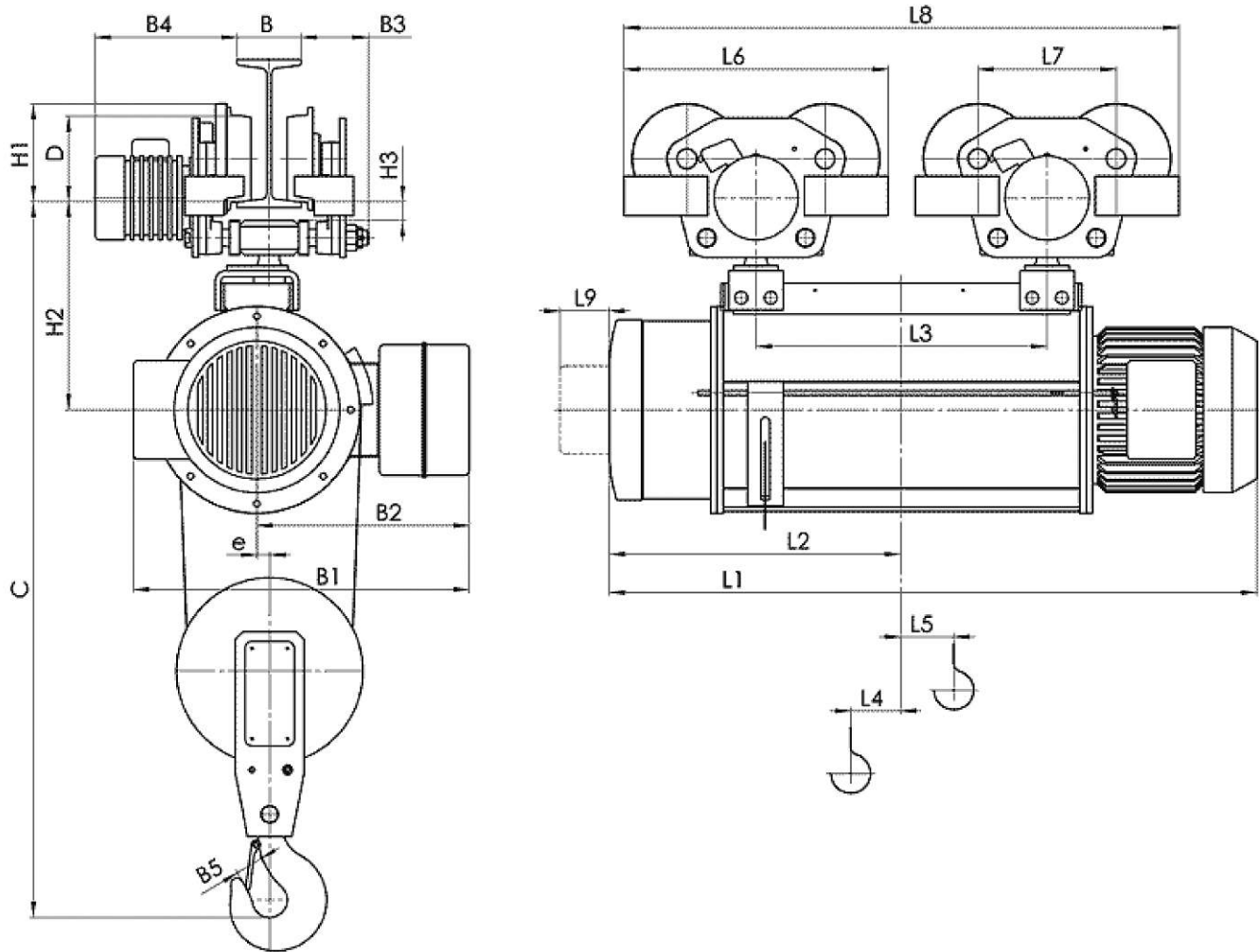

Electric wire rope hoists T10 Conveying one with two trolleys, reeving 2/1

(1) with micro-lifting

(2) with load limitation

(3) with load limitation and with micro-lifting

Type	Reeving 2/1		Dimensions, mm																							
	Lifting height, m	Lifting capacity, kg	Lifting speed m/min				L2	L3	L4	L5	L6	L7	L8	L9	H1	H2	H3	B	B1	B2	B3	B4	B5	e	C	D
			8	12	8/2	12/2																				
T102...	H4	18	500	978	1018	452	450	55	192	415	225	865	46	148	277	33	90...	465	300	94...	245...	34	18	930	120	
	H5	24		1138	1178	532	610	55	272			1025					110	492 ⁽¹⁾								365 ⁽²⁾
	H6	30		1226	1290	567	550	89	214	415	225	965	80	148	331	33	90...	580	380	94...	245...	34	22	1025	120	
	H7	36		1306	1373	602	620	110	228			1035					110	606 ⁽¹⁾								442 ⁽²⁾
T103...	H4	18	1000	1114	1154	512	570	75	231	415	225	985	70	200	277	33	90...	465	300	94...	245...	40	18	995	120	
	H5	24		1314	1354	612	770	149	332			1185					110	492 ⁽¹⁾								365 ⁽²⁾
	H6	30		1426	1490	667	750	90	312	415	225	1165	80	200	331	33	90...	675	430	94...	245...	40	22	1085	120	
	H7	36		1526	1593	712	840	110	338			1255					110	682 ⁽¹⁾								508 ⁽²⁾
T104...	H4	18	2000	1226	1290	567	550	90	212	536	280	1086	80	200	368	37	130...	580	380	125...	270...	45	22	1225	175	
	H5	24		1426	1490	667	750	90	312			1286					150	606 ⁽¹⁾								442 ⁽²⁾
	H6	30		1535	1623	710	800	88	346	536	280	1336	90	200	410	37	130...	675	430	125...	270...	45	26	1300	175	
	H7	36		1640	1728	762	905	75	398			1441					150	682 ⁽¹⁾								508 ⁽²⁾
T105...	H4	18	3200	1306	1373	602	620	110	226	536	280	1156	80	200	360	37	130...	580	380	125...	270...	50	22	1310	175	

Type	Reeving 2/1		Lifting speed m/min						
	Lifting height, m	Lifting capacity, kg	8	12	8/2	12/2	16	16/2.5	
			Weight, kg						
T102...	H4	18	500	119		137		226 272	
	H5	24		128		146		244 290	
	H6	30		250		297		251 297	
	H7	36		273		320		274 320	
T103...	H4	18	1000	218		241		330 376	
	H5	24		232		255		347 393	
	H6	30		375		422		376 422	
	H7	36		395		442		396 442	
T104...	H4	18	2000	459		506		664 719	
	H5	24		484		631		684 739	
	H6	30		691		786		731 786	
	H7	36		711		806		751 806	
T105...	H4	18	3200	504	514	569		686 741	
	H5	24		534	544	599		731 786	
	H6	30		721	761	816		761 816	
	H7	36		746	786	841		786 841	
T106...	H4	18	5000	656		751		998 1003	
	H5	24		706		801		1018 1023	
	H6	30		802		897		1038 1043	
	H7	36		1040		1100		1100 1105	
T107...	H2	9	8000	988		1048		1048 1053	
	H3	12		1036		1096		1096 1101	
	H4	18		1108		1168		1168 1173	
	H5	24		1175		1235		1235 1240	
	H6	30		1244		1304		1304 1309	
	H7	36		1314		1374		1374 1379	